

# Conductivity Measuring Sensor *InduMax P CLS 50*

**Highly resistant electrodeless conductivity measuring sensor for aggressive and high temperature applications**



The conductivity measuring sensor CLS 50 is suitable for use in the chemical industry and in process engineering. The six-decade measuring range and high chemical resistance of the material in contact with the medium (PFA/PEEK) permit this measuring sensor to be used in virtually any application conceivable. The wide temperature range of -4°F to +356°F (-20° to +180°C) leaves nothing to be desired.

#### **Areas of application**

- Concentration measurement of acids and bases
- Phase separation of product/product mixtures in pipe systems in food and pharmaceutical industry
- Product quality monitoring of chemical products in tanks and pipelines

#### **Benefits at a glance**

- To be used with Mycom CLM 153, MyPro CLM 431, MyPro CLD 431, Liquisys M CLM 223 / 253 measuring transmitter
- Measuring range from 0 mS/cm to 2000 mS/cm
- High chemical resistance due to PFA coating
- FM approved IS, NI; Class I, II, III; Division 1, 2; Groups A to G
- PEEK high temperature version for up to 356°F (180°C)
- Total cable length up to 180 ft (55 m)
- Dirt-repellent PFA surface with low friction factor
- Integrated, coated Pt 100 temperature sensor, error class A
- Large sensor opening with approximately 0.6" (15 mm), therefore, low risk of fouling
- Can be installed in tee pipes



# Measuring Principle

Measuring and operating principle

- 1 Measuring instrument
- 2 Cable
- 3 Transmitting coil
- 4 Sensor opening
- 5 Receiving coil
- 6 Sensor housing
- 7 Medium
- 8 Induced electric current

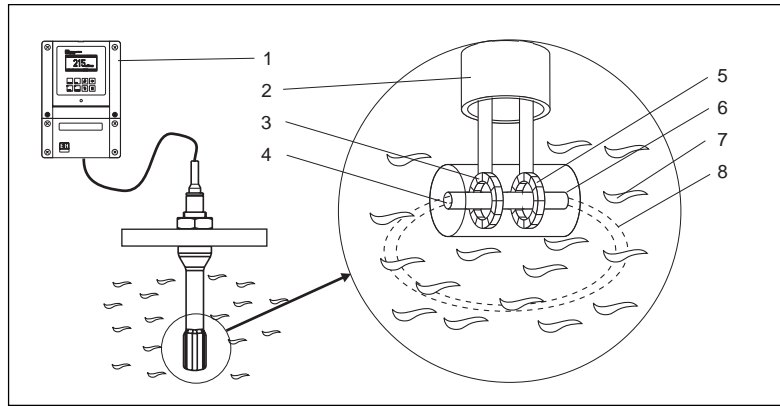

## Conductivity Measurement

In electrodeless conductivity measurement, a transmitting coil (3) generates a magnetic alternating field that induces an electric voltage in a liquid. The ions present in the liquid enable a current flow which increases with increasing ion concentrations. The ion concentration is proportional to the conductivity of the material. The current (8) in the liquid generates a magnetic alternating field in the receiving coil (5). The resulting current induced in the receiving coil is measured and used to determine the conductivity value.

This measuring principle has the following advantages:

- No electrodes, therefore no polarization
- Error-free measurement in strongly soiled media with a tendency to sediment
- Complete galvanic separation of measurement from medium

## Cell Constant and Installation Factor

The electric conductivity of the liquid primarily depends on the ion concentration. However, installation and sensor geometry are factors that need to be taken into account. The cell constant ( $k = 2 \text{ cm}^{-1}$ ) describes the geometry of the sensor completely.

If the distance from the wall is sufficient ( $a > 1''$ ), it is not necessary to consider the installation factor ( $f = 1.00$ ). If the distance from the wall is smaller, the installation factor increases in the case of electrically insulating pipes ( $f > 1$ ) and decreases in the case of electrically conductive pipes ( $f < 1$ ). See installation factor  $f$  chart, page 3.

## Installation

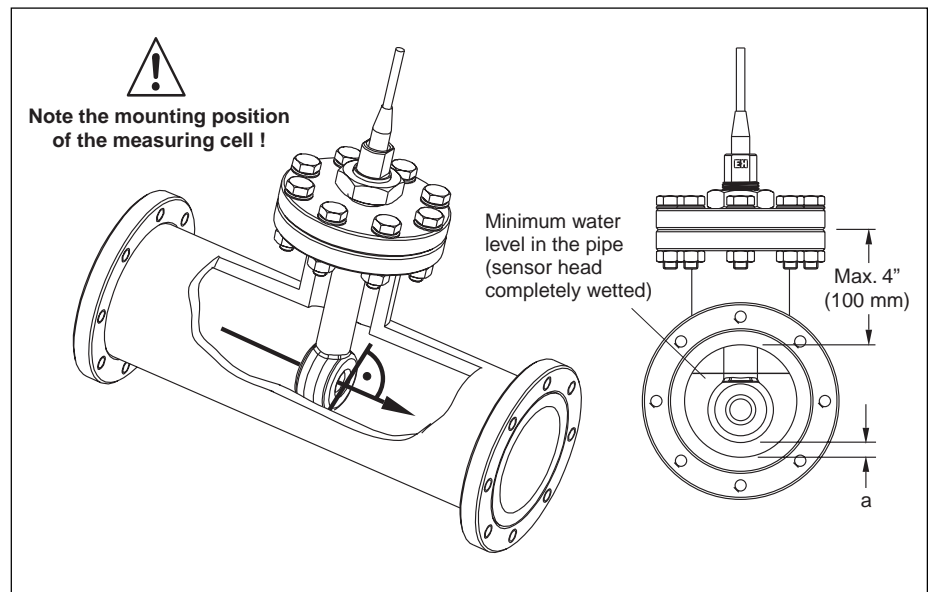
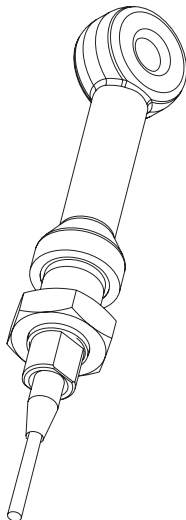

Installation factor (f)  
depending on distance  
from pipe wall  
1 Conductive pipe  
2 Insulating pipe

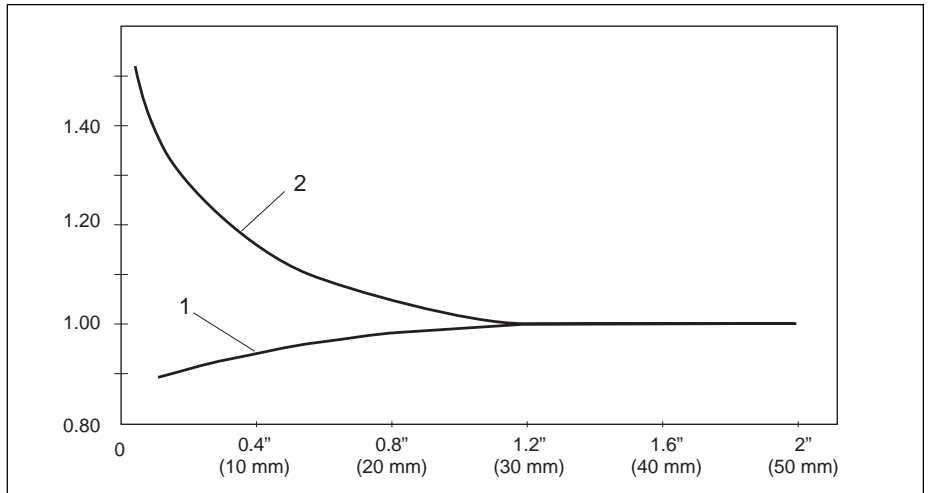

Endress+Hauser offers 4 immersion holder assemblies for closed or open tank or channel mounting.

- CLA 111 with suspension bracket  
Technical Information TI 135C/24/ae
- CLA 111 with flange mount  
Technical Information TI 135C/24/ae
- CLA 140 with flange mount  
Technical Information TI 196C/24/ae
- CYA 611 immersion assembly for basin or channel side wall mounting  
Technical Information TI166C/07/en

## Dimensions

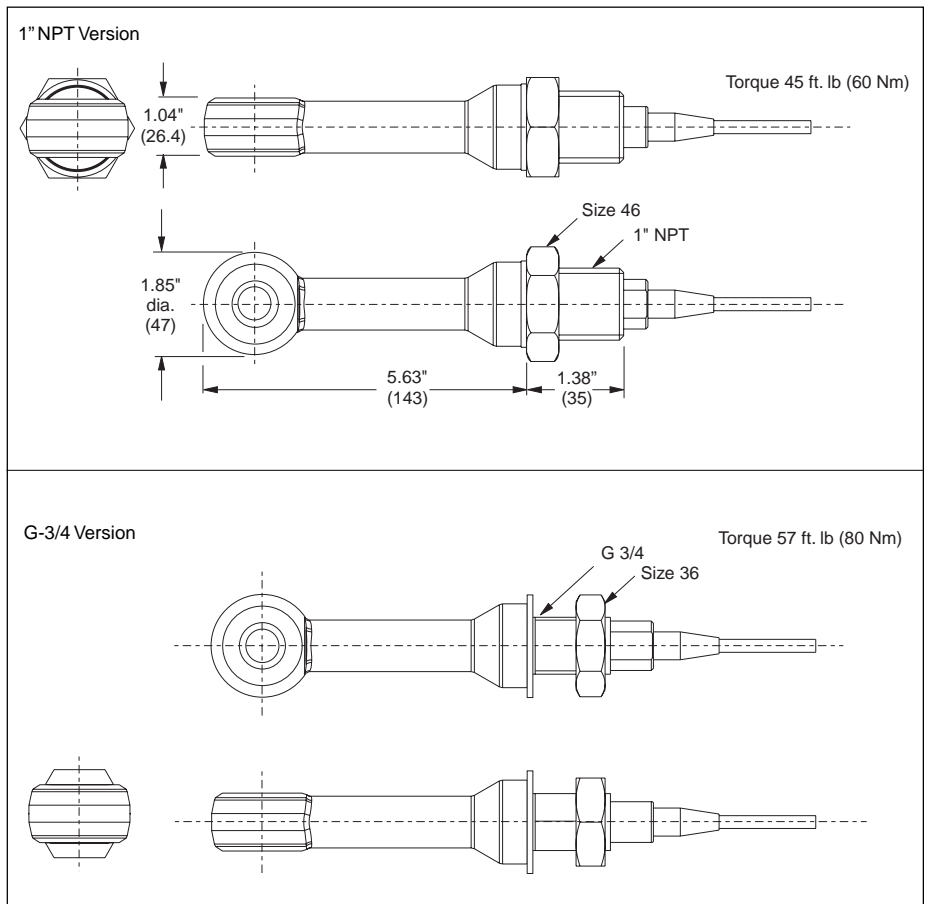

# Flange mounting measuring sensor

Flange not in contact with medium, fixed flange (process connections 5, 6, 7)

- 1 Nut
- 2 Flange
- 3 Sealing disk
- 4 Spacer ring
- 5 Sealing
- 6 Sensor

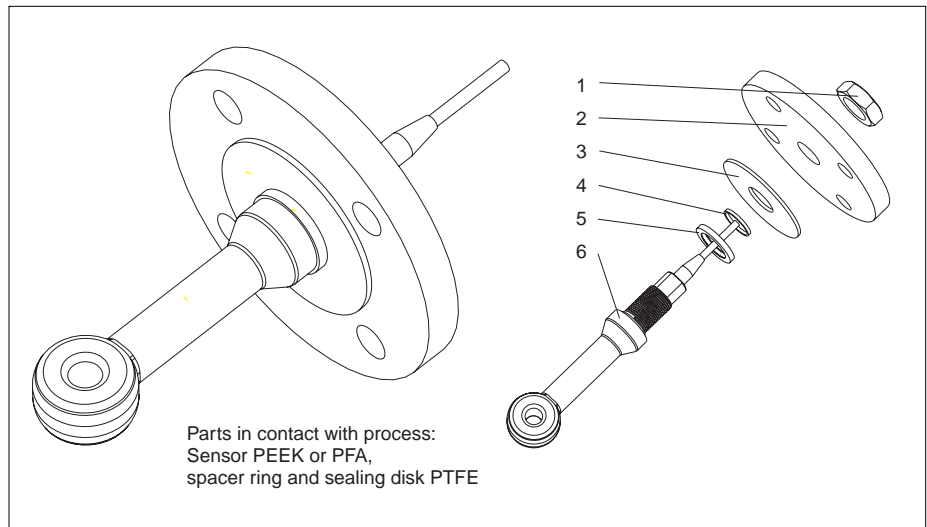

Flange in contact with medium

Top:  
Fixed flange (process connections 3, 4)

Bottom:  
Lap joint flange (process connections A, B, C)

- 1 Nut
- 2 Flange
- 3 Sealing
- 4 Sensor
- 5 Lap joint flange
- 6 Flange (PVDF)

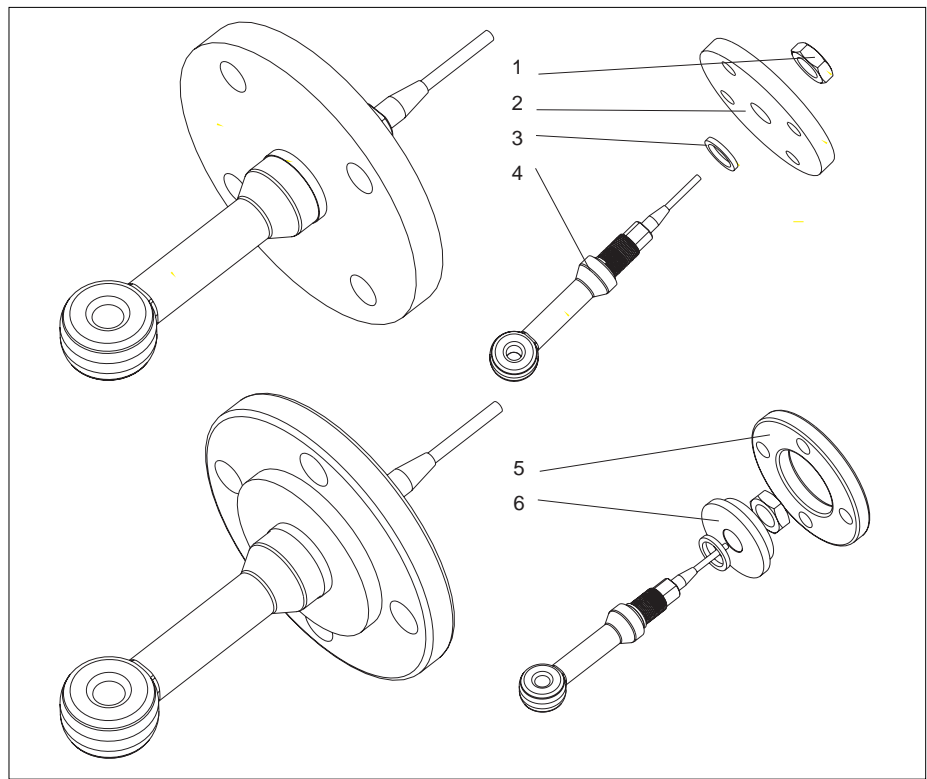

# Flange dimensions

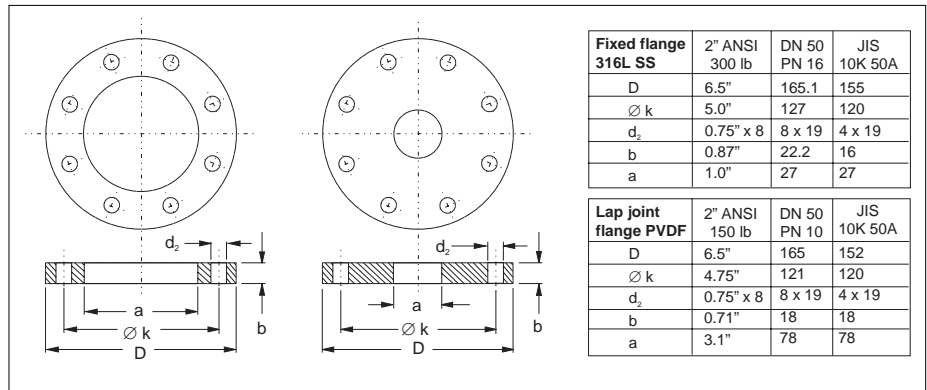

# Cable / cable connection

Sensor cable connection to Mycom S CLM 153

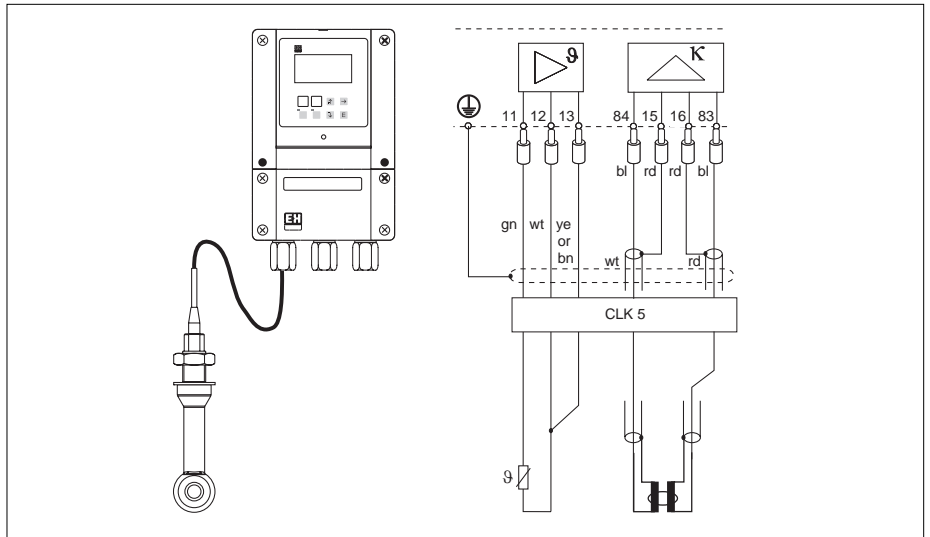

Sensor cable connection to MyPro CLM 431

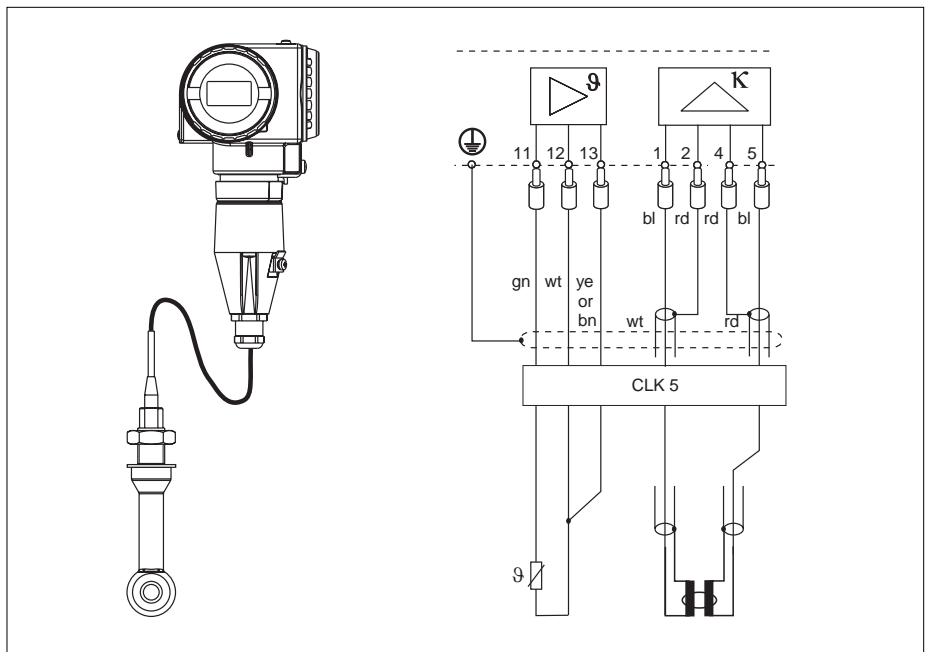

Sensor cable connection to Liquisys M 223/253

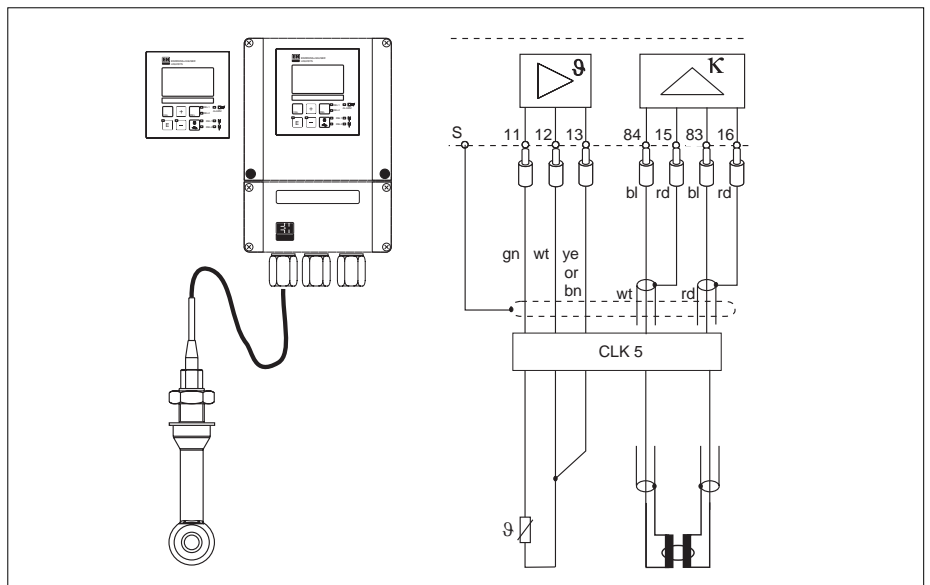

# Resistance table

Chemical attack			Resistance	
Medium	Concentration (%)	Temperature	PFA	PEEK
Nitric acid (HNO <sub>3</sub> )	5	68°F (20°C)	+	+
		140°F (60°C)	+	+
	up to 40	68°F (20°C)	+	+
		140°F (60°C)	+	-
Phosphoric (H <sub>3</sub> PO <sub>4</sub> )	up to 10	68°F (20°C)	+	+
		140°F (60°C)	+	+
Sodium hydroxide (NaOH)	3	68°F (20°C)	+	+
		122°F (50°C)	+	+
		176°F (80°C)	+	+

Resistances  
PEEK and PFA  
+ resistant  
- not resistant

# Pressure-temperature curves

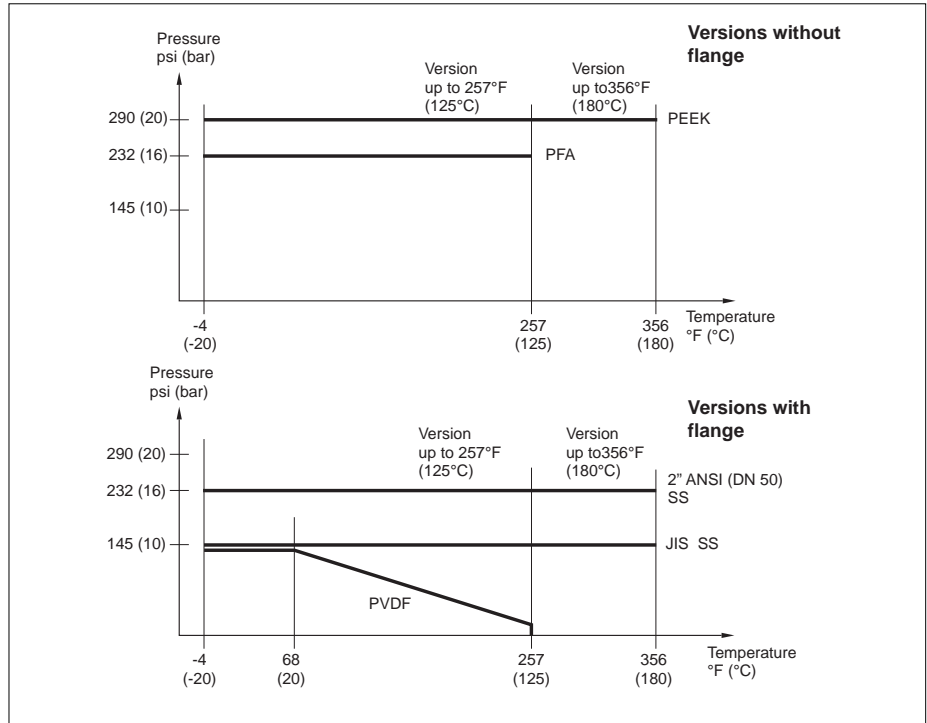

Pressure-temperature curves are dependent on the flange version and material

# Technical Data

## General Specifications

Manufacturer	Endress+Hauser Conducta
Designation	CLS 50
Measuring Range	0 mS/cm to 2000 mS/cm
Cell Constant	Approximately 2 cm <sup>-1</sup>
Storage Temperature	-4° to +176°F (-20° to + 80°C)
Protection Type	NEMA 6P
Measured Value Deviation	For 68° to 212°F (20° to 100°C), ± 5 μS/cm + 0.5% of measured value For > 212°F (100°C), ± 10μS/cm + 0.5% of measured value

## Temperature measurement

Temperature Sensor	Pt 100, Class A, according to IEC 751
Temperature Response t <sub>90</sub>	90% or upper temperature display limit (according to DIN 746-1)
- PEEK version	Approximately 7 minutes
- PFA version	Approximately 26 minutes

## Process Installation

Required Pipe Diameter	≥ 3" (DN 80), consider installation factor if pipe diameter < 4" (DN 110)
Installation in Reduced Outgoing Line	≥ 2" (DN 50)

## Accessories

Measuring extension cable CLK 5  
 NOTE: Maximum cable length between sensor and transmitter when using cable extension and junction box is 180 feet (55 m) PN: 50085473

VBM junction box for cable extension, with 10 screw terminals, NEMA 4X (IP 65)  
 1/2" NPT cable entry PN: 50003987  
 Pg 13.5 cable entry PN: 51500177

### Calibration Solutions

Calibration solutions are precision solutions to SRM (Standard Reference Material) of NIST for qualified calibration of conductivity measuring systems according to ISO, accuracy ±0.5%, with temperature table. Reference temperature is 77°F (25°C). Solutions are in 500ml containers.

74 μS/cm	PN: 50081902
149.6 μS/cm	PN: 50081903
1.406 mS/cm	PN: 50081904
12.64 mS/cm	PN: 50081905
107 mS/cm	PN: 50081906

# Ordering Information

Conductivity Measuring Cell CLS 50 -  1  2  3  4

- 1 Certificate
  - A Version for non-Ex area
  - G EEx ia IIC T4/T6, ATEX II 1G
  - M Certified I M2 EEx ia I
  - O FM approved, IS, NI, Class I, II, III; Div. 1, 2; Grps A-G
  - S CSA IS, NI, Class I, II, III; Div. 1, 2; Grps A-G
  - T TIIS
- 2 Process Connection / Material
  - 1 G 3/4 / 316Ti SS
  - 2 1" NPT / PEEK
  - 3 DN 50, PN 16 / 316L SS
  - 4 2" Class 300 ANSI flange / 316L SS
  - 5 DN 50, PN 16 / 316L SS, PTFE flange seal
  - 6 2" Class 300 ANSI flange / 316L SS, PTFE flange seal
  - 7 JIS 10K 50A / 316L SS, PTFE flange seal
  - A DN 50 PN10 / PVDF flange
  - B 2" Class 150 ANSI flange / PVDF
  - C JIS 10K 50A flange / PVDF
- 3 Probe Material
  - A PFA with PTFE seal
  - B PEEK with Viton seal
  - C PEEK with PTFE seal
- 4 Temperature Range / Cable Length
  - 1 Max. 255°F (125°C) / 16 foot (5 m)
  - 2 Max. 255°F (125°C) / 33 foot (10 m)
  - 3 Max. 255°F (125°C) / 65 ft (20 m)
  - 4 Max. 255°F (125°C) / Specify length in meters (priced per meter)
  - 5 Max. 356°F (180°C), PEEK only / 16 foot (5 m)
  - 6 Max. 356°F (180°C), PEEK only / 33 foot (10 m)

## Supplemental Documentation

- Mypro CLM 431 / CLD 431
- Mycom S CLM 153
- Liquisys M CLM 223 / 253
- TI 172C/24/ae
- TI 234C/24/ae
- TI 193C/24/ae

For application and selection assistance, in the U.S. call 888-ENDRESS

For total support of your installed base, 24 hours a day, in the U.S. call 800-642-8737

Visit us on our web site, [www.us.endress.com](http://www.us.endress.com)

### United States

Endress+Hauser, Inc.  
2350 Endress Place  
Greenwood, IN 46143  
Phone: (317) 535-7138  
888-ENDRESS  
FAX: (317) 535-8498

### Canada

Endress+Hauser  
Canada Ltd.  
1440 Graham's Lane  
Unit 1, Burlington  
ON, L7S 1W3  
Phone: (905) 681-9292  
800-668-3199  
FAX: (905) 681-9444

### Mexico

Endress+Hauser  
Paseo del Pedregal No. 610  
Col. Jardines del Pedregal  
01900, Mexico D.F.  
Mexico  
Phone: (525) 568-2405  
FAX: (525) 568-7459

Endress+Hauser  
The Power of Know How

