

# Dissolved Oxygen Measurement *liquisys M COM 223 F / 253 F*

## Oxygen Controller



Liquisys M COM 253 F

Liquisys M COM 223 F

Due to the modularity of its design, the Liquisys S COM 223 F / 253 F controller can be adapted to a wide range of customer needs. The basic version, which provides simple measuring and alarm signaling functions, can be equipped with additional software and hardware modules to match specific applications. Retrofitting of expansion modules is also possible.

### Areas of application

- Process control in enzyme production
- Control of culture preparations
- Biotechnological production

### Benefits at a glance

- Measuring controller in field or panel-mounted housing
- Universal application
  - Switchable between oxygen concentration in mg/l and saturation index in % SAT via software switching (mg/l = ppm)
- Simple handling
  - Logically arranged menu structure with plain text in 6 languages facilitates instrument configuration
  - Large, two-line display indicates measured value and temperature at the same time
  - Simple one-point calibration in air or in the medium
- Safe Operation
  - Overvoltage (lightning) protection according to EN 61000-4-5
  - Direct access for manual contact control

*The basic unit can be extended with:*

- 2 or 4 contacts for use as:
  - Limit contacts (also for temperature)
  - PID controller
  - Timer for simple rinse processes
  - Complete cleaning with Chemoclean
- Plus package:
  - Any current output configuration via table
  - Automatic initiation of cleaning in case of alarm or limit violation
  - Live check of sensor
  - Process monitoring
- HART® or PROFIBUS-PA / -DP
- 2nd current output for temperature

**Details**

Liquisys M COM 223 F / 253 F provides a solution for all water and waste water treatment applications.

Features of the **basic version (HX)**:

**Measurement of oxygen concentration in mg/l or % saturation**

This is selected via the menu. The **temperature** is displayed at the same time or, if desired, not shown at all.

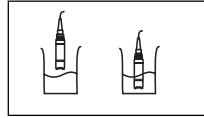

The COS 41 sensor has no zero current and therefore only requires **one-point calibration**. This is performed in air (corresponding to 100% saturation) or by reference calibration in the medium.

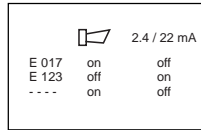

Different alarms are required depending on application and operator. Therefore the Liquisys M COM 223 F / 253 F permits independent **configuration of the alarm contact and error current** for each individual error. Unnecessary or undesirable alarms can be suppressed in this manner.

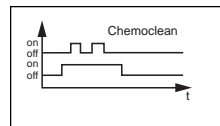
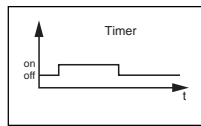

**Up to four contacts** can be used as limit contacts (also for temperature), to implement a PID controller or for cleaning functions.

Direct **manual operation of the contacts** (bypassing the menu) provides quick access to limit, control or cleaning contacts, permitting speedy correction of deviations.

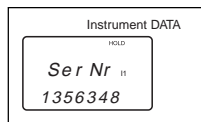

The **serial numbers** of the instrument and modules and the order code can be called up on the display.

The **HS version** provides **additional functions**:

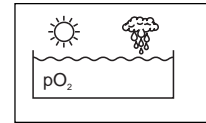

The oxygen concentration not only depends on the local altitude, but also on the weather (air pressure). The **automatic pressure compensation** function takes these fluctuations into account.

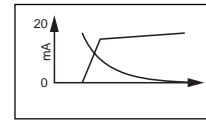

In order to display wide measuring ranges while still achieving a high resolution in specific ranges, the **current output** can be configured as required via a table. This permits **bilinear** or **quasi-logarithmic** curves.

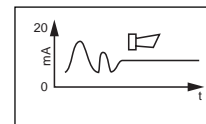

The **live check** issues an alarm when the sensor signal does not change over a defined period of time. This may be caused by blocking, passivation, or separation from the process.

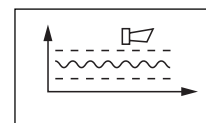

The **Process Check System** is used to monitor adjustable time intervals, e.g. for permanent aeration or permanent absence of aeration.

Errors in applications **without** control are detected by monitoring the limit between plausible and implausible measured values, i.e. the **alarm threshold**.

Errors in applications **with** control are detected by the **controller monitor** which monitors freely adjustable, maximum permissible time intervals and reference value overshoot or under-shoot.

## Basic Version and Plus Package

Basic Version	With plus package (DS version)
<b>Alarm signaling</b> MEASUREMENT CALIBRATION Read instrument DATA  Linear CURRENT OUTPUT CURRENT OUTPUT simulation 1 programmable ALARM CONTACT (contact and error current)	<b>Alarm signaling</b>  PROCESS CHECK SYSTEM for monitoring, e.g. of aeration  LIVE CHECK of sensor  CURRENT OUTPUT programmable (table)
<i>Additional features</i>	<i>Additional features</i>
<b>Controlling</b> 2 CHANGEOVER CONTACTS for - Measuring parameter limit - Temperature limit - PID controller - Timer for cleaning	<b>Controlling</b>  Automatic cleaning triggered by alarm or limit violation
<i>Additional features</i>	<i>Additional features</i>
<b>Cleaning</b> 2 more CHANGEOVER CONTACTS (total of 4) for - Measuring parameter limit - Temperature limit - PID controller - Chemoclean cleaning (water and cleaning agent)	<b>Cleaning</b>  Cleaning triggered externally or automatically by alarm or limit violation

## Measuring and Control System

A complete measuring system comprises:

- the oxygen controller Liquisys M COM 223 F or COM 253 F
- an oxygen sensor COS 41 with an integrated NTC temperature sensor
- an immersion, flow or retractable holder

Options:

- extension cable (type CMK 71), and
- junction box VBM

Complete measuring system with transmitter Liquisys M COM 223 F or 253 F

- 1 Oxygen sensor OxyMax H COS 21 (sold separately)
- 2 Retractable holder assembly CleanFit H CPa 475 (sold separately)
- 3 Measuring cable CYK 71
- 4 Field mounted COM 253 F
- 5 Panel mounted COM 223 F

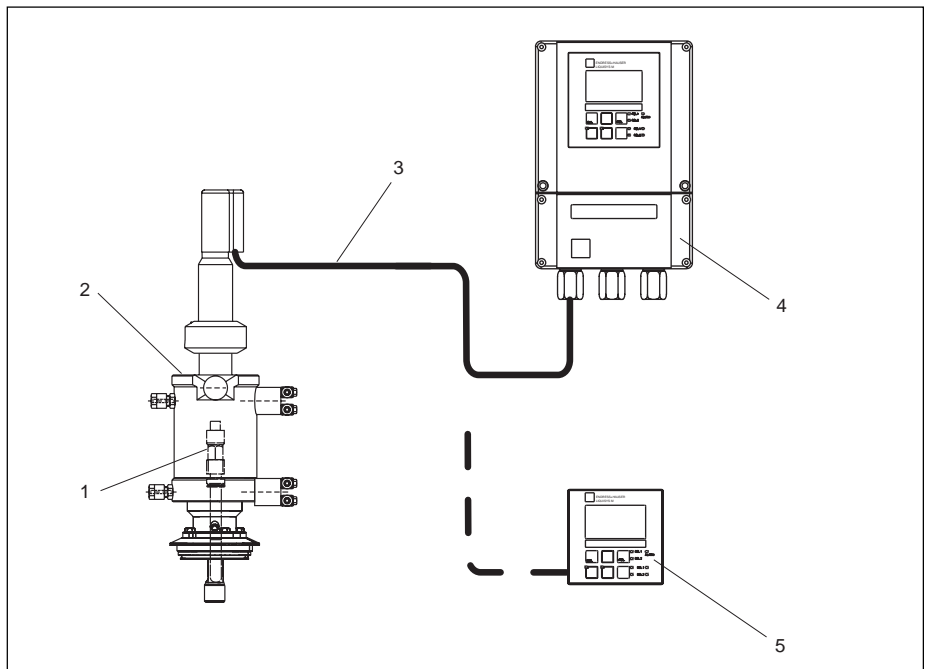

# Operation

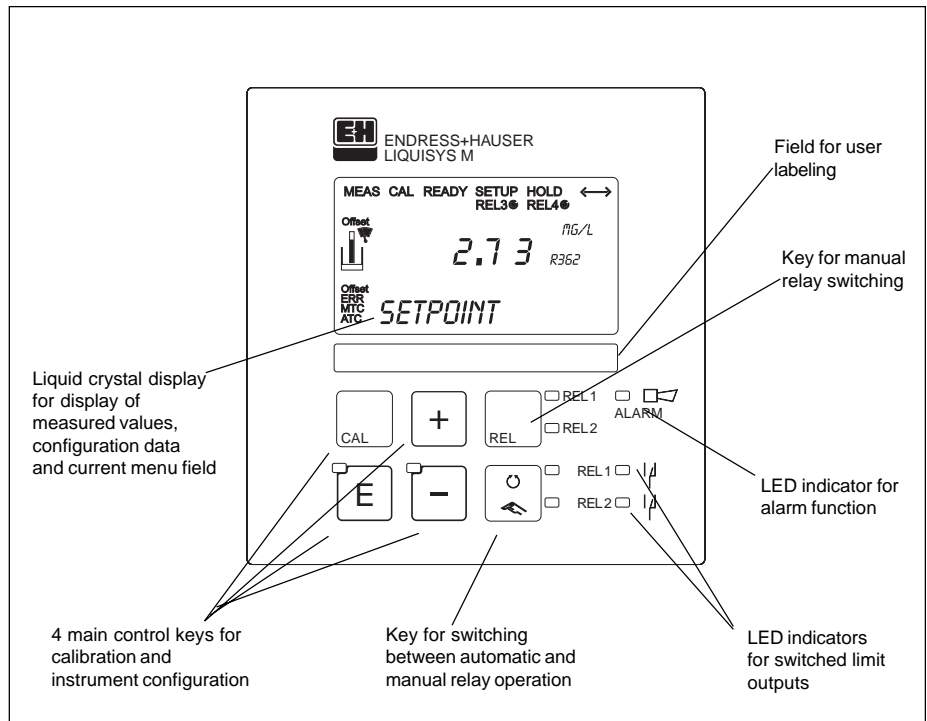

User interface:  
Display and keys

## Everything at a glance

The display simultaneously shows the current measured value and the temperature – the essential process data. Brief informational texts in the configuration menu provide assistance with parameter configuration.

## Intelligent and simple

All instrument control functions are arranged in a logical menu structure. Following access code entry, the individual parameters can be easily selected and modified as needed.

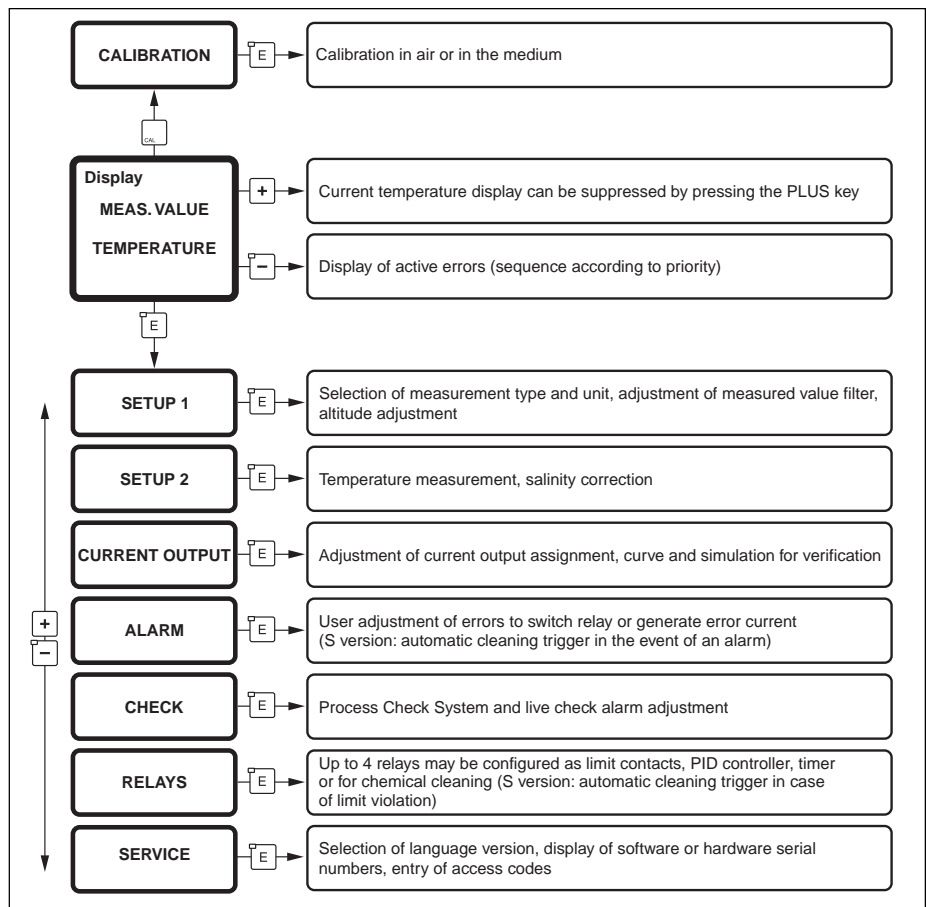

Overview of Liquisys M  
COM 223 F / 253 F menu.  
This covers all  
the options that can be  
installed (see page 2  
Details).

## Electrical Connection

All connections to the panel-mounted instrument COM 223 F are established via the terminal strips on the rear. In the case of the field instrument COM 253 F, all wires (including the sensor cable) are connected to terminals in a separate wiring compartment.

All the wiring can remain in place if the instrument needs repair because all repairs are limited to assembly replacement. Dismantling the instrument and rewiring is not necessary.

*Left:*  
Liquisys M COM 223 F,  
connections on the rear  
of the instrument

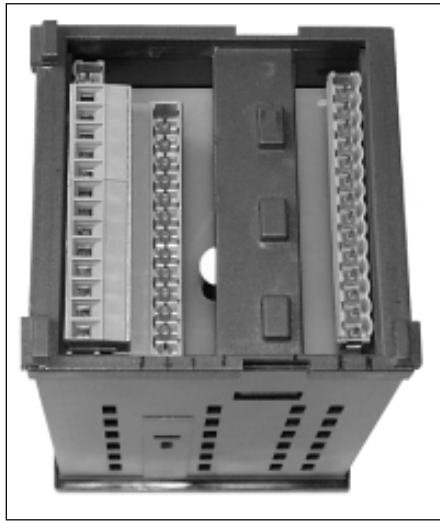

*Right:*  
Liquisys M COM 253 F,  
rear of instrument with  
replaceable electronics  
box (E)

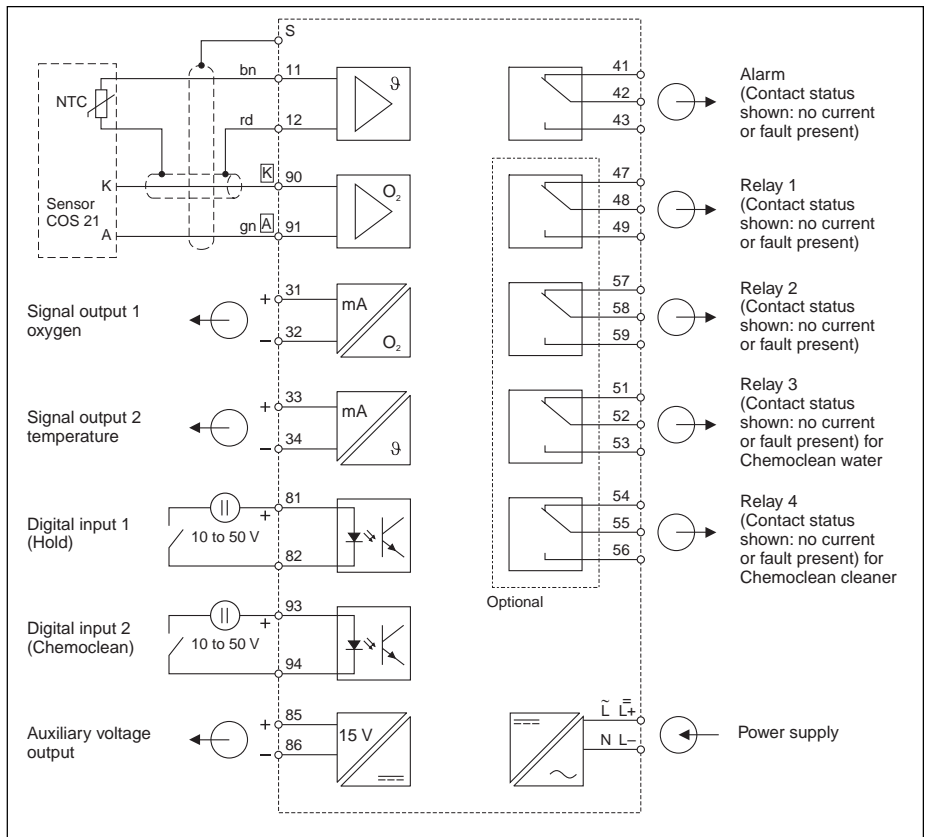
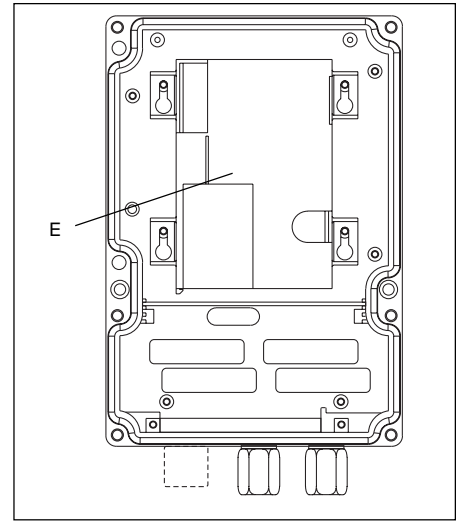

Electrical connection of  
Liquisys M COM 223 F / 253 F

**Dimensions**

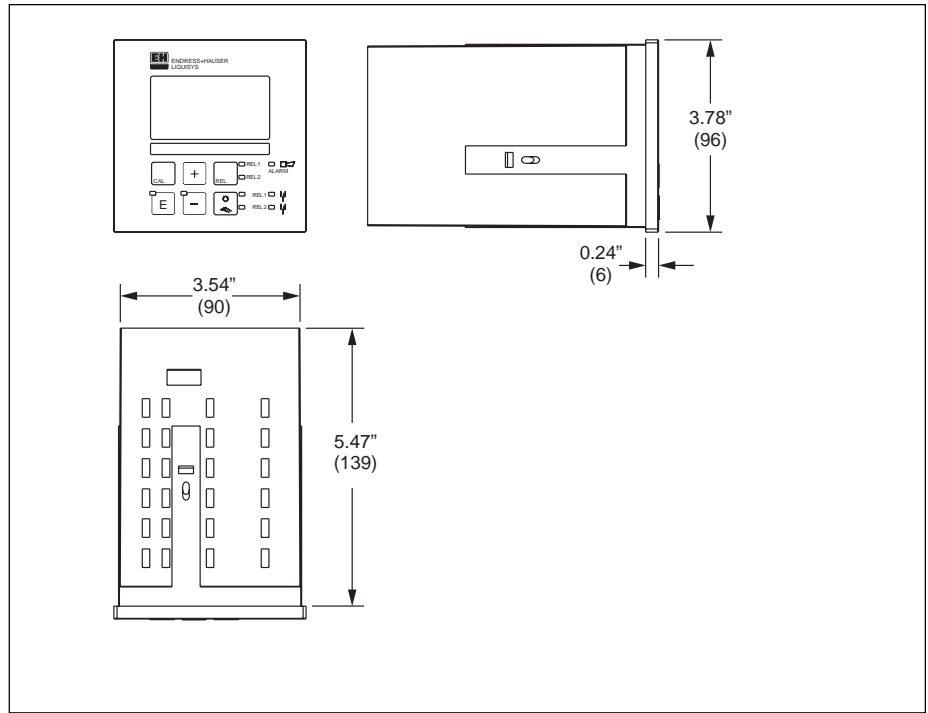

Dimensions of  
Liquisys M COM 223 F

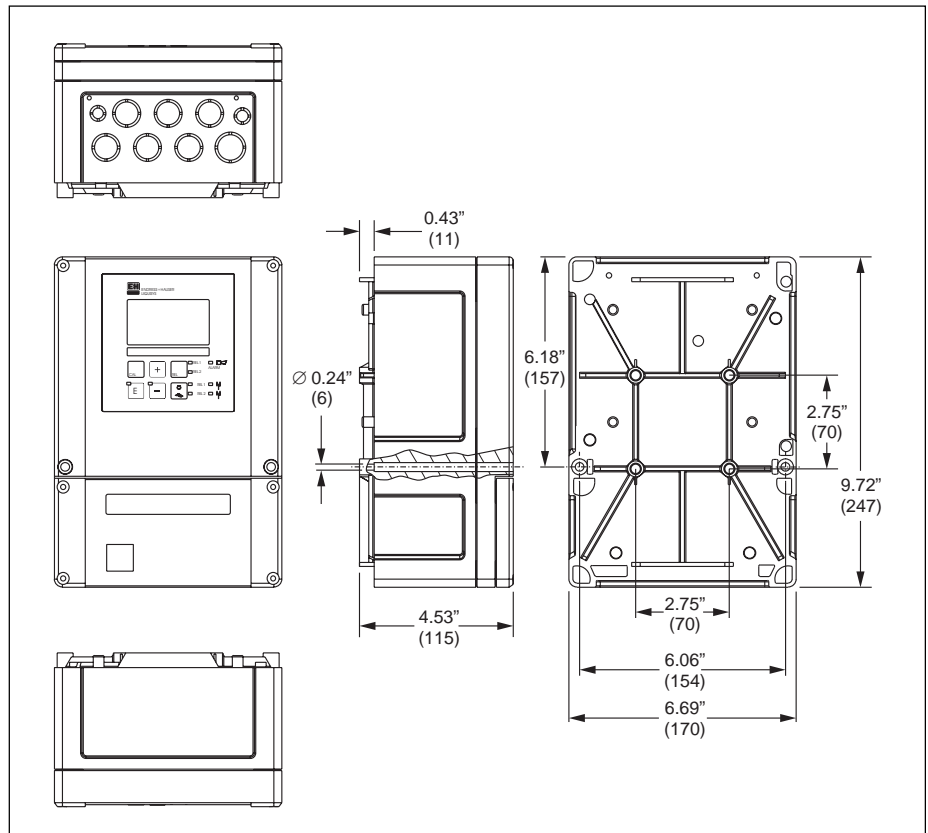

Dimensions of  
Liquisys M COM 253 F

**Mounting of  
Liquisys M COM 223 F**

The panel-mounted version is mounted using the supplied tensioning screws. The required overall mounting depth is approximately 6.5 in. (165 mm).

Installation of panel-mounted housing

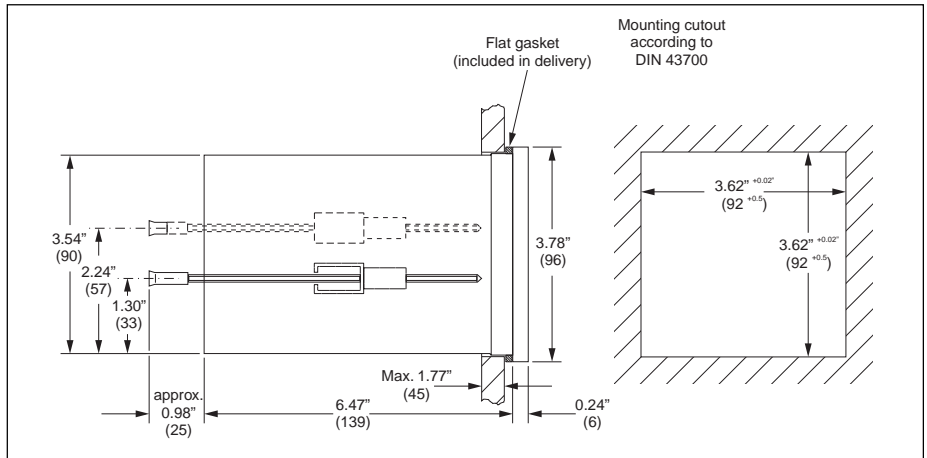

**Installing the Liquisys M COM 253 F**

There are several installation options for the field mounted housing:

- Attachment to a square mounting post
- Attachment to cylindrical pipe
- Wall mounting with fixing screws

For outdoor operation, the weather protection cover CYY 101 is required. It can be mounted on the field device in all installation types.

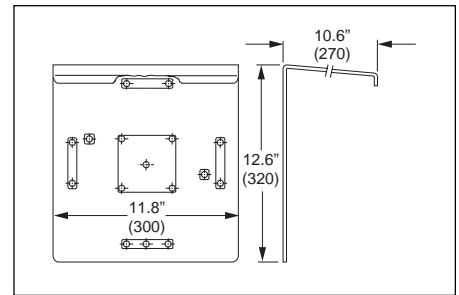

Weather protection cover CYY 101  
(see Accessories)

To attach the enclosure to a square mounting post (using universal upright post CYY 102 or upright post suspension assembly, CYH 101), proceed as follows:

- ① Mount the weather protection cover on the upright post
- ② Mount the field enclosure from the rear to the weather protection cover

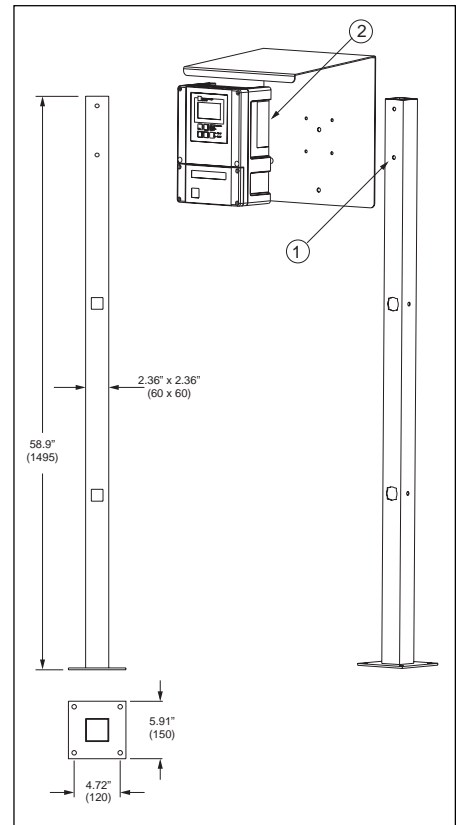

Universal upright post CYY 102  
or the upright post (identical design  
for the suspended assembly CYH 101).

**Mounting of  
Liquisys M COM 253 F**

Post mounting kit for installation of field housing on cylindrical pipes (horizontal or vertical, max.  $\varnothing$  2.36" (60 mm); see Accessories)

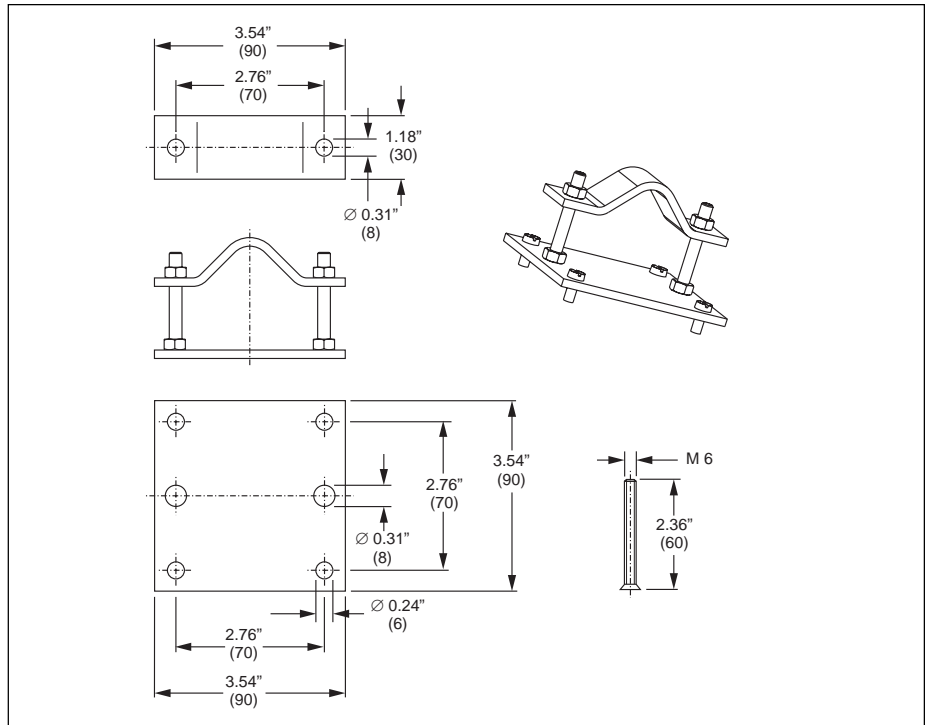

Mounting on cylindrical pipes (shown with weather protection cover installed on right)

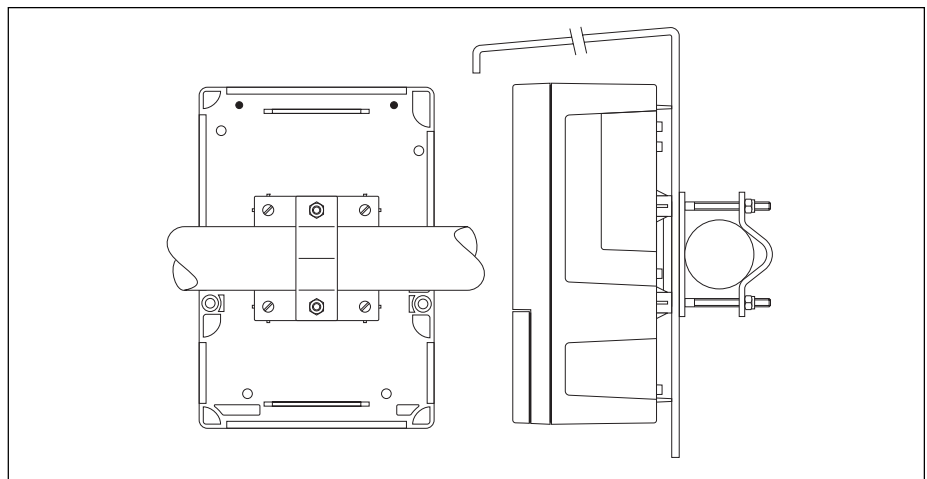

Wall mounting  
Screws:  $\varnothing$  0.24" (6 mm)  
Anchors:  $\varnothing$  0.31" (8 mm)

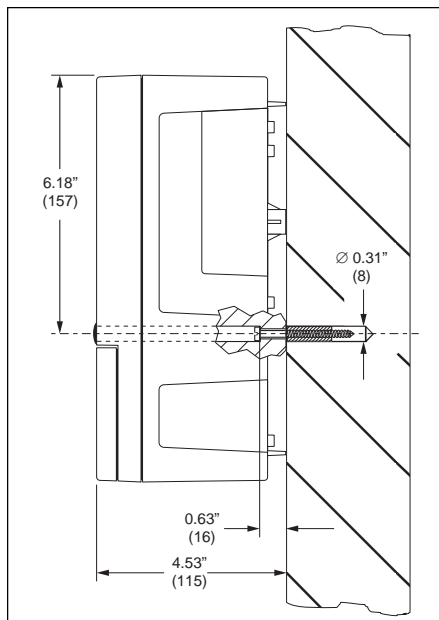

## Technical Data

### General specifications

Manufacturer	Endress+Hauser
Product designation	Liquisys M COM 223 F Liquisys M COM 253 F

Measured quantities	O <sub>2</sub> / temperature
---------------------	------------------------------

### Input

#### O<sub>2</sub> measurement with sensor COS 21

Display and measuring range	0.1 to 20 mg/l or 0 to 200% SAT (1 mg/l = 1 ppm)
Temperature compensation range	0 to 122 °F (0 to 50 °C)
Pressure compensation range (optional)	500 to 1100 hPa
Altitude adjustment range	0 to 13,300 ft. (0 to 4000 m)
Salinity adjustment range	0 to 4%

#### O<sub>2</sub> signal input

Signal current	0 to 650 nA
Nominal slope (sensor in air, 20 °C, 1013 mbar)	290 nA
Maximum length of cable to sensor	160 ft. (50 m)

#### Temperature measurement

Temperature sensor	NTC, 30 kΩ at 77 °F (25 °C)
Display range	+14° to +140°F (-10 to +60°C)

#### Digital inputs 1 and 2

Voltage	10 to 50 V
Current consumption	max. 10 mA

### Output

#### O<sub>2</sub> signal output

Current range	0 / 4 to 20 mA, galvanically separated; error current 2.4 / 22 mA
Load	max. 500 Ω
Maximum resolution	700 digits/mA
Transfer range with COS 21	Δ 0.2 to Δ 20 mg/l or Δ 20 to Δ 100% saturation
Isolation voltage	max 350 V <sub>rms</sub> / 500 V DC
Overvoltage (lightning) protection	acc. to EN 61000-4-5: 1995

#### Temperature signal output (optional)

Current range	0 / 4 to 20 mA, galvanically separated
Load	max. 500 Ω
Maximum resolution	700 digits/mA
Transfer range	Δ 7 to Δ 70°C
Isolation voltage	max 350 V <sub>rms</sub> / 500 V DC
Overvoltage (lightning) protection	acc. to EN 61000-4-5: 1995

#### Auxiliary voltage output

Output voltage	15 V ± 0.6 VDC
Output current	max. 30 mA

#### Contact outputs (floating changeover contacts)

Switching current with ohmic load (cos φ = 1)	max. 2 A
Switching current with inductive load (cos φ = 0.4)	max. 2 A
Switching voltage	max. 250 V AC, 30 V DC
Switching power with ohmic load (cos φ = 1)	max. 1250 VA AC, 150 W DC
Switching power with inductive load (cos φ = 0.4)	max. 500 VA AC, 90 W DC

#### Limit contactor

Limit adjustment range	0 to 20 mg/l or 0 to 200% SAT or 4° to 140°F (-10 to +60°C)
Pickup / dropout delay	0 to 7200 seconds

# Technical Data (continued)

## Output (continued)

### Controller

Function (adjustable)	Pulse length / pulse frequency controller
Controller response	P, PI, PD, PID
Controller gain $K_p$	0.01 to 20.00
Integral action time $T_n$	0.0 to 999.9 min.
Derivative action time $T_v$	0.0 to 999.9 min.
Period for pulse length controller	0.5 to 999.9 seconds
Frequency for pulse frequency controller	60 to 180 min <sup>-1</sup>

### Alarm

Function (switchable)	steady / fleeting contact; normally closed / open
Alarm threshold adjustment range	0 to 20 mg/l or 0 to 200% SAT or 4° to 140°F (-10 to +60°C)
Alarm delay	2 to 2000 seconds
Monitoring time for lower limit violation	0 to 2000 min
Monitoring time for upper limit violation	0 to 2000 min

## Accuracy

### O<sub>2</sub> measurement with sensor COS 21

Resolution	0.01 mg/l or 0.1% SAT
Measured error <sup>1</sup> display	± 0.03 mg/l, ± 0.3% SAT
Repeatability	± 0.05 mg/l, ± 0.5% SAT
Measurement deviation <sup>1</sup> , O <sub>2</sub> signal output	max. 0.75% of measuring range

### Temperature measurement

Resolution	0.2 °F or 0.1 °C
Measured error <sup>1</sup> display	max. 1.0% of measuring range
Measurement deviation <sup>1</sup> , temperature signal output	max. 1.25% of current output range

## Ambient conditions

Nominal operating temperature	14 to 131 °F (-10 to +55 °C)
Ambient temperature (limit operating conditions)	-4 to 140 °F (-20 to +60 °C)
Storage and transport temperature	-13 to 149 °F (-25 to +65 °C)
Relative humidity (nominal operating conditions)	10 to 95%, non-condensing
Protection class of panel-mounted unit	NEMA 3S (IP 54, front), IP 30, housing
Protection class of field housing	NEMA 4 (IP 65)
Electromagnetic compatibility	interference emission acc. to EN 50081-1: 1992 interference immunity acc. to EN 50082-2: 1995

## Physical data / design

Dimensions of panel-mounted unit (H x W x D)	3.78 x 3.78 x 5.71 in. (96 x 96 x 145 mm)
Installation depth	approx. 6.5 in. (165 mm)
Dimensions of field housing (H x W x D)	8.73 x 6.10 x 8.46 in. (204 x 155 x 215 mm)
Weight of panel-mounted unit	max. 1.54 lb. (0.7 kg)
Weight with field housing	max 5.07 lb. (2.3 kg)
Display	LC display, two lines, five and nine digits, with status indicators

### Materials

Housing of panel-mounted unit	polycarbonate
Front membrane	polyester, UV-resistant
Field housing	ABS PCFr or PCFr (CSA general purpose)

## Power requirements

Supply voltage	100 / 115 / 230 V AC +10 / -15%, 48 to 62 Hz 24 V AC/DC +20 / -15%
Power consumption	max. 7.5 VA
Fuse protection	fine-wire fuse, medium time-lag, 250 V / 3.15 A

<sup>1</sup>acc. to IEC 746-1, for nominal operating conditions

Subject to modifications.

## Accessories

### Mounting accessories

- Weather protection cover CY 101: for mounting on field housing, for outdoor installation. 12.6" H x 11.8" W x 10.6" D (320 x 300 x 270 mm), 304 SS  
Order no. CYY 101-A
- Universal upright post CYY 102: square tubing for mounting field housing. 59" H x 2.4" W x 2.4" D (1495 x 60 x 60 mm), 304 SS  
Order no. CYY 102-S

### Sensor holder assemblies

- UniFit H CPA 442: sterilizable process holder for fixed installation, meets 3-A sanitary standards and EHEDG certificate. For 120 mm sensors.  
Technical Information and order information: TI 306C/24/ae
- ProbFit H CPA 465: sterilizable retractable assembly, meets 3-A sanitary standards and EHEDG certificate. For 350 mm sensors  
Technical Information and order information: TI 146C/24/ae

### Sensor

- OxyMax H COS 21: sterilizable sensor for dissolve oxygen  
Technical Information and order information: TI 244C/24/ae

### Connection accessories

- Measuring cable COK 21 for COS 21:
  - 3 ft (1 m) length Order no. 51505871
  - 10 ft (3 m) length Order no. 51505870
  - 16 ft (5 m) length Order no. 51505869
  - 33 ft (10 m) length Order no. 51505868
- Extension cable CYK 71: non-terminated measuring cable for oxygen sensors (sold by meter) Order no. 50085333
- VBM junction box for measuring cable extension between sensor and transmitter  
Order no. 50003987

### Device upgrade

When upgrading the COM transmitter, please specify the serial number of your unit.

- Plus package Order no. 51506469
- Chemoclean Order no. 51500963
- Two-relay card Order no. 51500320
- Four-relay card Order no. 51500321

## Product structure

### Oxygen transmitter Liquisys M COM 223 F / COM 253 F

COM 223 F - 

1	2	3	4
---	---	---	---

- 1 Version
  - HX Oxygen measurement with COS 21 (basic functions)
  - HS Oxygen measurement with COS 21 with additional functions
- 2 Power Supply
  - 0 230 VAC
  - 1 115 VAC
  - 2 230 VAC, CSA general purpose
  - 3 115 VAC, CSA general purpose
  - 5 100 VAC
  - 7 24 VAC / VDC, CSA general purpose
  - 8 24 VAC / VDC
- 3 Measurement output
  - 0 Oxygen
  - 1 Oxygen and temperature
  - 3 Profibus PA
  - 4 Profibus DP
  - 5 Oxygen with HART
  - 6 Oxygen with HART and temperature
- 4 Contacts
  - 05 No additional contacts
  - 10 2 contacts (limit / PID / timer)
  - 15 4 contacts (limit / PID / Chemoclean)
  - 16 4 contacts (limit / PID / timer)

COM 253 F - 

1	2	3	4
---	---	---	---

- 1 Version
  - HX Oxygen measurement with COS 21 (basic functions)
  - HS Oxygen measurement with COS 21 with additional functions
- 2 Power Supply
  - 0 230 VAC
  - 1 115 VAC
  - 2 230 VAC, CSA general purpose
  - 3 115 VAC, CSA general purpose
  - 5 100 VAC
  - 7 24 VAC / VDC, CSA general purpose
  - 8 24 VAC / VDC
- 3 Measurement output
  - 0 Oxygen
  - 1 Oxygen and temperature
  - 3 Profibus PA
  - 4 Profibus DP
  - 5 Oxygen with HART
  - 6 Oxygen with HART and temperature
- 4 Contacts
  - 05 No additional contacts
  - 10 2 contacts (limit / PID / timer)
  - 15 4 contacts (limit / PID / Chemoclean)
  - 16 4 contacts (limit / PID / timer)

For application and selection assistance,  
in the U.S. call 888-ENDRESS

For total support of your installed base, 24 hours  
a day, in the U.S. call 800-642-8737

Visit us on our web site, [www.us.endress.com](http://www.us.endress.com)

---

#### United States

Endress+Hauser, Inc.  
2350 Endress Place  
Greenwood, IN 46143  
Phone: (317) 535-7138  
888-ENDRESS  
FAX: (317) 535-8498

#### Canada

Endress+Hauser  
Canada Ltd.  
1440 Graham's Lane  
Unit 1, Burlington  
ON, L7S 1W3  
Phone: (905) 681-9292  
800-668-3199  
FAX: (905) 681-9444

#### Mexico

Endress+Hauser  
Paseo del Pedregal No. 610  
Col. Jardines del Pedregal  
01900, Mexico D.F.  
Mexico  
Phone: (525) 568-2405  
FAX: (525) 568-7459

---